

Cell Phone Based Devices Control using Microcontroller with Voice Acknowledgement

¹Galbale V.S. and ²Dhawale S.M.

^{1,2}Assistant professor, Electronic Science Dept, MIT ACSC, Alandi(D), Pune, Maharashtra (India)

ARTICLE DETAILS

Article History

Published Online: 22 Dec 2018

Keywords

Microcontroller, Cell Phone, DTMF, Audio Recorder, Handheld Mobile Terminal, Soil Moisture Sensor.

Corresponding Author

Email: vsgalbale[at]mitacsc.ac.in

Vaibhavgalbale[at]gmail.com

ABSTRACT

This paper introduces the intelligent farming control system, the system is developed through microcontroller, embedded C operating system, and this paper is an implementation of the idea of the wireless communication between a mobile phone and a microcontroller. They have to go to the remote area and ON/OFF the appliance. Cell phone used (GPS-module) wireless communication technology and network technology. It gives the overall framework of hardware and software design and describes ways to implement the system. User can control appliances through hand-held mobile terminal.

1. Introduction

In an India near about 60-70% people doing farming hence called agriculture country. This is purely based on embedded system as all its operations are controlled by intelligent program inside the microcontroller. This project is used to control ON/OFF three phase motor more efficient, reliable and ensure safety, by making simple call by handheld terminal mobile. Now days storage of underground water and rainfall level slowly falling down and hence it is necessary to supply the optimum quantity of water, and It also helps the farmer to give water the crops in proper schedule as per Farmer can ON/OFF water pump as per them and water conservation also .

2. Objectives

- To coordinate appliance and the device through simple call by the cell phone used by the user.
- To effectively receive and transmit data by cell phone.
- To eliminate the need of being physically present in any location for tasks involving the operation appliances within farm or household or industry.
- To Minimize power, water and time wastage.
- To protect motor from dry run and power supply (Electricity).

3. Experimental Section

This system we use 3-phase signal detection, motor control(ON/OFF), soil moisture, dry run, voice acknowledge message, here we used simple basic microcontroller AT89s52 were programmed is done by using keil IDE software. For example, when the user wants to ON/OFF the device; he has to make simple call in his mobile defining the messages by pressing key from keypad of cell phone, for example key 0 is pressed then get a result as 'MOTOR ON' in voice message is heard to client, the microcontroller inside the system is programmed in such a way that when the modem receives any message the microcontroller will read the message from serial

headphone and verify for the pressed key, if it is correct then it will start performing the desired task one by one. The figure shows block diagram of proposed system.

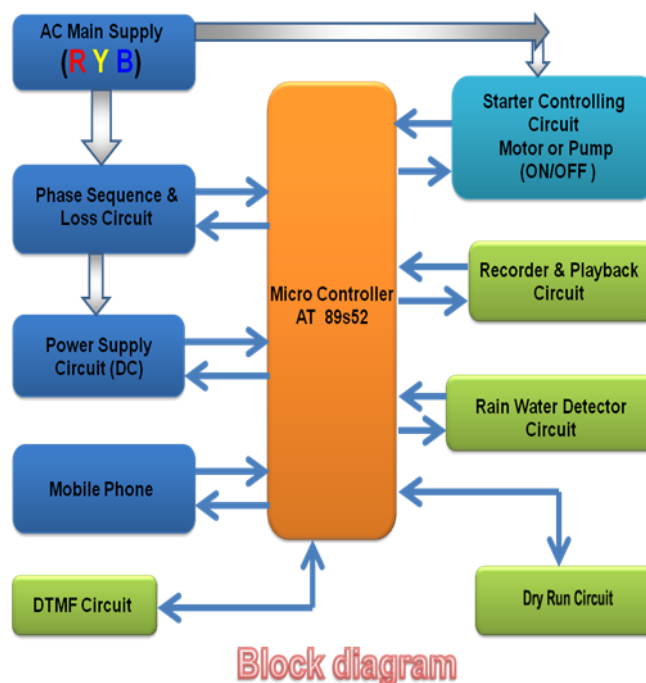

3.1. Phase sequence and loss circuit:

We also designed other circuits for the same after some time and build a proper and perfect circuit for the phase sequence and loss which gives us correct and proper output means we check the circuit manually by doing the phase absent for example by removing any one fuse from the three phase board, the RED led glows which means that sequence or phase is absent In this circuit we use MCT2E opto-coupler IC's, diodes 1N4007, resistor 33kΩ 2W, capacitors, Inverter IC7414, dual D-flip flop 7474 and 7411 three terminal AND gate IC.

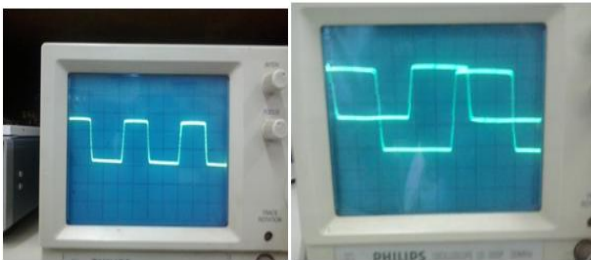
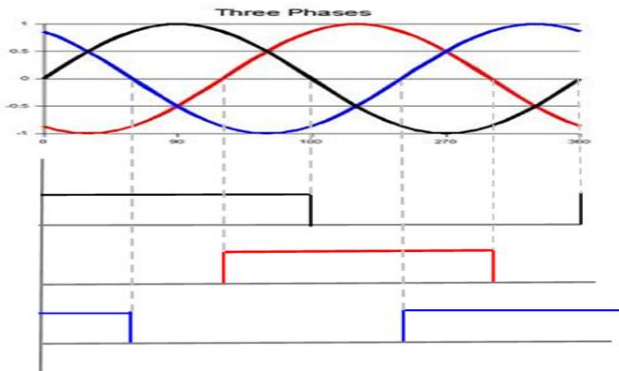
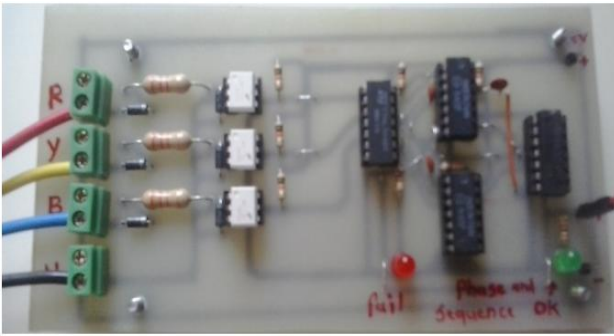

Above two figures show the three phase sequence and loss checker circuit. We have taken three phase connection from the main source of three phase provided in the departmental lab to phase sequence and loss circuit, in this we can checked whether three phase are present or absent. At first we checked the opto-coupler output and it gave square-wave on the CRO (Cathode Ray Oscilloscope) which showed 120 degree of phase shift between three phase signals. IC 7414 inverting Schmitt trigger, which inverts the output and gives sharpness to the square wave. We have used IC 7474 Dual positive edge D flip flop for checking the phase sequence and losses. We have also used IC 7411, three-terminal AND-gate for checking the presence of all three phases and if so the IC gives high at its output. For this we have connected two LED's respectively for indication.

3.2 Power supply with three phases

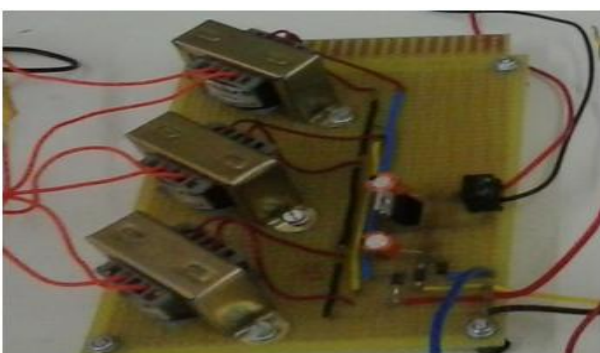

In this we used three transformers of range 230V AC 0-9V/0.25A, which are connected to three phase of supply board and this is the power supply which gives constant 5V regulated power supply and also gives three phase supply to the circuit.

- The above figure shows a simple regulated power supply (5v dc). In this first we connect the three phase board to the power supply circuit which having three transformers.
- Transformer input, means at primary we give 230V AC supply and at the secondary output gives 0-9v and 250 mA which is connected with diodes 1N4007 are used as rectifier then for filter, capacitor of value 220uf is used after that we use 7805 IC which regulate 5V dc power supply and capacitor regulate 7805 output. We also use green LED for indication.
- This power supply is design for special function, if any one or two phase are absent among three phases after that we will get regulate 5V dc power supply to our circuit.
- It will not work only and only when all three phases are absent.

3.3 Remote mobile, DTMF, microcontroller and APR33A3 circuit

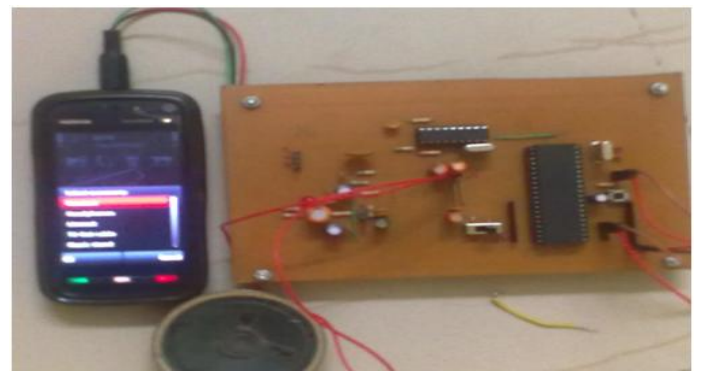

Voice acknowledge system in Farming Using Microcontroller

- The above figure shown is the heart of the project, which consists of remote mobile, DTMF, microcontroller and APR33A3.
- First we connected the headset pin to the remote mobile, before that we must have to do some changes in the remote mobile settings such as keep mobile on automatic answer mode that means when we make call on remote mobile it will automatically answer.
- For checking we first made call to the remote mobile and it will automatically receive, after that press '*' button or key from user mobile, we get recording status of the signal for example press key '1' for motor ON.
- First this signal is fed to the DTMF (Dual tone multiple frequency) circuit, it will decode the input signal means convert into binary for example when key '1' is pressed, we get (0001) in binary then pass these value of signal to the microcontroller.
- Microcontroller get the input signal from DTMF and check the conditions such as phase sequence and loss, whether motor is running dry or not, there is rain fall or not and motor status etc. if all conditions are satisfied or working well then and then motor will start or turn ON.

While if any one of conditions are not satisfied from the above, motor is OFF and gives voice acknowledgment message for example motor is OFF due to dry run or electricity problem or rainfall and pass this signal to APR33A3 block.

- This all messages are store in the APR33A3 voice and playback circuit, which having a capacity to store eight message. When the specific message signal is received from microcontroller, then the voice and playback circuit plays a specific message.

3.4 Relay driver circuit

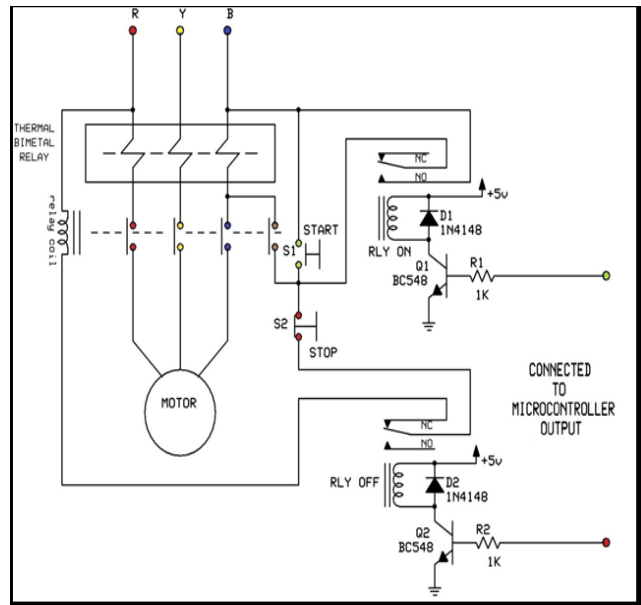
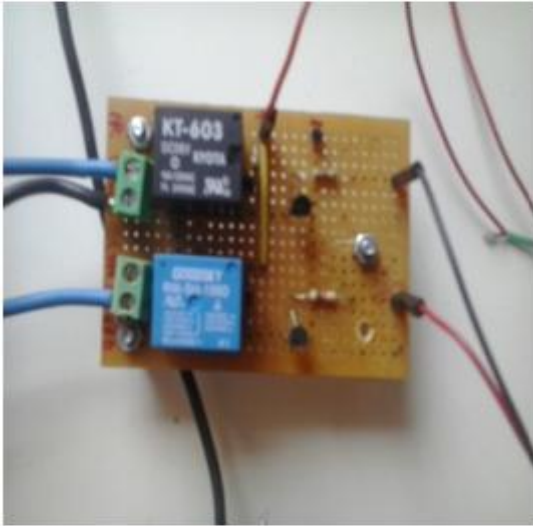

3.5 Dry run

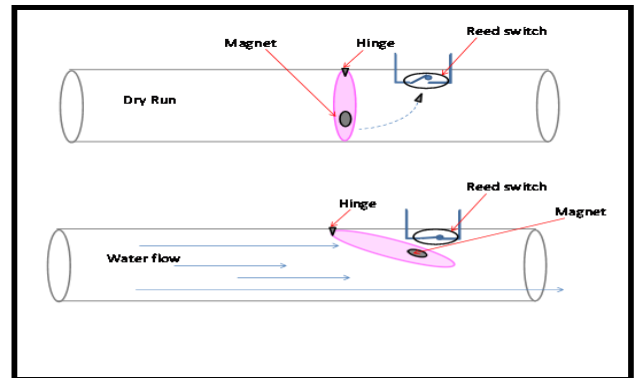

For the safety of motor pump it will check motor is running without water, which causes motor damage or burn.

3.6 Rain water detector

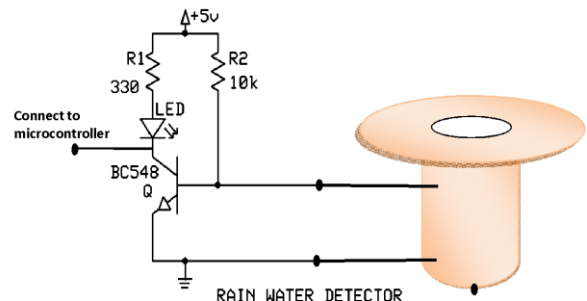

Rain water detector means we will detect the presence of rain i.e. without being present at that site we will be able to know the condition of rainfall whether it is present or absent. So that the farmer will be able to know about rainfall on his mobile and will take proper action that is whether to give water to the crops and turn ON or OFF the motor.

The above figure shows the simple circuit for rain water detection means it gives information to the microcontroller that sufficient amount of rain has fallen and there is no need to give

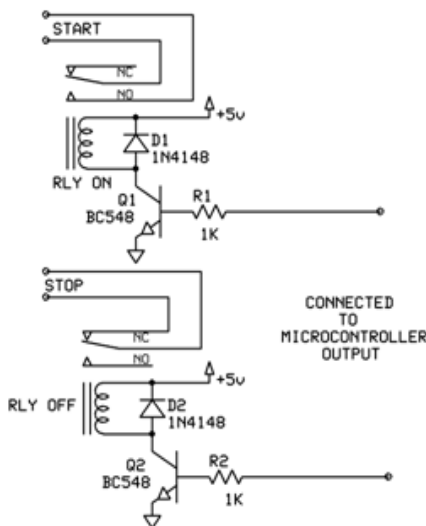

The above figure and circuit shows the relay driver circuit, which we are use to start and stop the motor or motor starter.

- To START/ON the motor, we get high signal from the microcontroller to the transistor Q1 to ON, as soon as the transistor will ON the relay is also ON means starter is ON.
- To STOP/OFF motor, we get high signal from the microcontroller to the transistor Q2 to OFF as soon as the transistor will ON the relay is also ON means starter is OFF.

water externally to crops. The above circuit consists of two resistors, one LED for indication and a transistor. To know whether sufficient amount of rain has fallen, we have used a vessel like conical flask. Initially when there is no rainfall, the LED will be ON, also the transistor will be ON due to pull-up resistor connected to Vcc and the collector of transistor will be nearly equal to zero and low signal will be fed to the microcontroller.

If there is sufficient amount of rain falling in the farm then, the level connected in the vessel will be in contact with water and hence the transistor will become OFF thus giving high signal to the microcontroller.

4. Result

We tested all the circuits separately and connected them properly to make one project circuit. Then we tested whole circuit that is we repeated the procedure of testing one-by-one and got the correct output or the result.

- **Three phase power supply –**
 - We checked the AC 230 V on each phase
 - Also checked line voltage ($\approx 400V$)
- **Power supply-**
 - We checked first if all phases are connected to power supply it gives 5V dc output.
 - Then we removed the one phase and after that we got 5V dc output.
 - Finally we checked if any one phase is present it gives 5V dc output.
- **Phase sequence and loss circuit-**
 - First we checked the opto-coupler output
 - We checked the D-FF output
 - And then we checked the final sequence and loss output on the AND gate IC.
- **DTMF, Microcontroller and APR33A3 -**
 - First we checked the DTMF output
 - Then we checked the Microcontroller output.
 - And then we checked the record and playback.

References

1. Vasif Ahmed and S. A. Ladhake, "Design of Ultra Low Cost Cell Phone Based Embedded System for Irrigation," Intl. Conf. on Machine Vision and Human-machine Interface, Kaifeng, China, 24-25th April 2010, pp 718-721.
2. Hassan K, Siddiqui RI, Islam MT, Siddiqui NA, and Udin SME. (2013) GSM Based Automatic Motor Control and Protection System. International Journal of Advancements in Research & Technology, Vol.2, Issue 2
3. Kumbhar SR, Ghatule AP. (2013). Microcontroller based Controlled Irrigation System for Plantation. Proceedings of the International MultiConference of Engineers and Computer Scientists, Volume II, March 2013.
4. Deepak Gupta, Amit Kushwaha, Mohammad Sikander, Shushma Trivedi, Precision Agriculture for Drip Irrigation Using Microcontroller and GSM Technology, Int. Journal of Engineering Research and Applications www.ijera.com ISSN : 2248-9622, Vol. 4, Issue 6 (Version 5), June 2014, pp.229-233.
5. M.D. Singh & K.B. Khanchandani, "Power Electronics" Tata McGraw Hill
6. Electronics for You Magazine (EFY)

- **Starter relay circuit –**
 - First we checked manually, by giving 5v to the relay one for ON starter
 - And then gives to second relay for OFF starter.
 - Finally we checked automatically ON/OFF the starter through microcontroller.
- **Dry run detector –**
 - We checked the dry run circuit manually by moving hinge towards reed switch.
- **Rain water circuit –**
 - We checked the rain water circuit by pouring the water into the vessel which we used and got the output.

Finally we checked the whole circuitry and did motor ON/OFF and also checked all the conditions such as rain fall, phase sequence and loss and dry run

5. Conclusion

In this paper we describe that there are many alternatives for controlling device individually but the Purposes of our system is to control a task in multiple ways and make system more reliable, efficient and time Consuming. As well as reduced the farmer effect & also for security purpose we provide a unique identification System. We hope our project is being change in agricultural section as well as industrial level motor controlling system.

Limitation: Motor or Pump is start (ON) and stop (OFF) only in the presence of mobile network. It takes few seconds to operate the motor.

Acknowledgement

One of the authors Galbale V.S. would like to thanks Prof. Dr.B.B.Waphare, Principal and Head of Electronic Science Department, MIT Arts Commerce & Science College, Alandi (D), Pune